

User's Manual

For

CCS_SHB45A and CCS_SHB60A

Smart H-bridge

Revision 1.0

©2024 All Rights Reserved

Attention: Please read this manual carefully before using the driver!

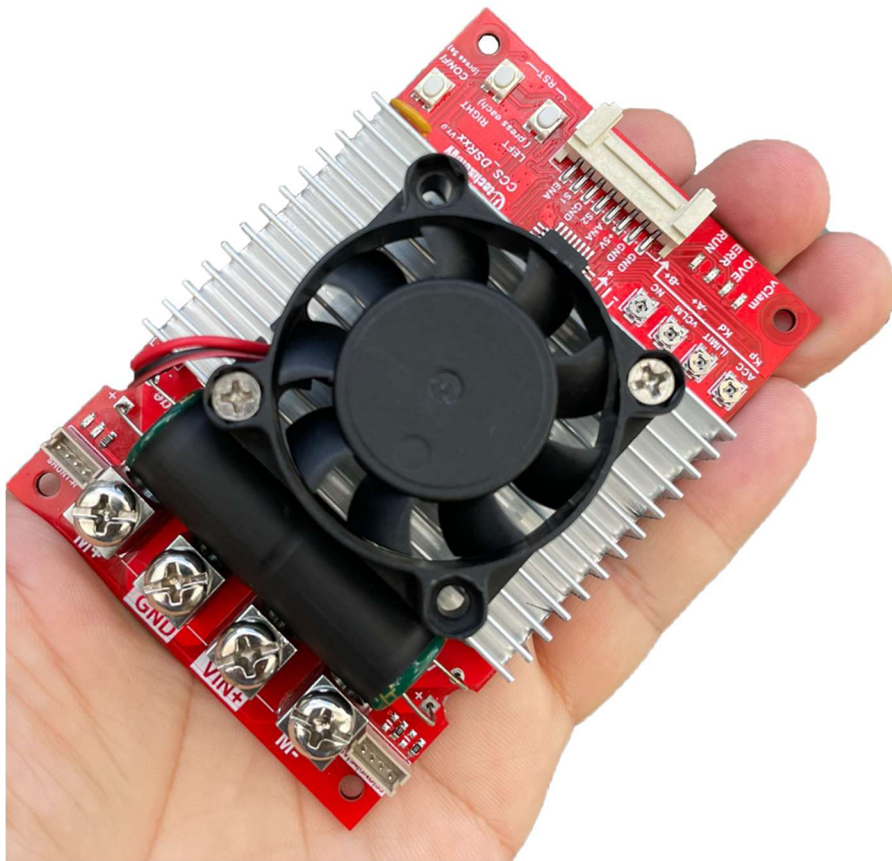

Cc-Smart Technology Co., Ltd

1419/125 Le Van Luong, Phuoc Kien Commune, Nha Be District, Ho Chi Minh City, Viet Nam.

Tel: +84983029530 Fax: No

URL: www.cc-smart.net E-mail: ccsmart.net@gmail.com

The content in this manual has been carefully prepared and is believed to be accurate, but not responsibility is assumed for inaccuracies.

Cc-Smart reserves the right to make changes without further notice to any products herein to improve reliability, function or design. Cc-Smart does not assume any liability arising out of the application or use of any product or circuit described herein; neither does it convey any license under its patent rights of others.

Cc-Smart's general policy does not recommend the use of its products in life support or aircraft applications wherein a failure or malfunction of the product may directly threaten life or injury. According to Cc-Smart's terms and conditions of sales, the user of Cc-Smart's products in life support or aircraft applications assumes all risks of such use and indemnifies Cc-Smart against all damages

**©2024 by Cc-Smart Technology Company Limited.
All Rights Reserved**

Table of Contents

1. Introduction, Features and Applications.....	3
Introduction.....	3
Features.....	4
2. Specification and Operating Environment	4
Mechanical Specification.....	4
Elimination of Heat.....	5
Electrical Specifications	5
Operating Environment and Parameters	5
3. Connections (Note: Please Setting Mode by CONF button)	6
General information	6
PWM Bi Direction (or PWM50/50) Mode Connection:	7
PWM/DIR Mode Connection:	8
ANALOG/DIR Mode Connection:.....	8
UART Mode Connection:.....	9
RC Independent Mode Connection:	9
ANALOG Joystick or ANALOG 50/50 Mode Connection:.....	10
4. UART Command Feature:	10
Address = (para+1)	10
UART Parameter.....	10

UART Command:.....	10
5. Configuration:.....	11
Input type Configuration:	11
Acceleration/Deceleration Configuration:	12
6. Protection & Indication Feature:.....	14
Protection:.....	14
Indication:	14
7. ENABLE/STATUS Pin Feature:.....	15
8. Recommendation:	15
Wire Gauge.....	15
System Grounding.....	15
Power Supply Connection.....	15

1. Introduction, Features and Applications

Introduction

The driver is big smart H-Bridge Driver which is designed to control a very big brushed DC motor about the speed and direction. The Motor is controlled by MOSFETs with 16 KHz switching to optimum performance and noise.

The driver support **Acceleration/Deceleration** feature. This feature will help protect the Electric, Mechanical...It will useful for many applications.

The driver also supports two **Electric Current Home Sensor inside** to limit the moving left and right. The user doesn't need more extended limit switch. This driver will monitor the current when the Motor running, if the current of the Motor same as with the iLimit (iLimit is a current limit setting by potentiometer in PCB), the driver will set a Touched Flag and stop moving that direction. To moving, the driver need control by reverse direction or the Touched Flag need to be clear.

The driver supports many protection method as **Under voltage, Over voltage, Over temperature, Over Current**. These protects feature are very important witch help to keep protection system.

Special, The Smart H-bridge support all most common communication methods. The user is easy to choose that method by the Dip Switch in Pcb:

- ✓ PWM/Dir
- ✓ PWM Bi-direction
- ✓ Analog/Dir
- ✓ Analog Bi-Direction
- ✓ Uart Network
- ✓ PPM Independ signal (RC).

Features

- ✓ 1 Channel.
- ✓ 10-55VDC Supply
- ✓ 45A/60A Continuously Current, 100A/150A peak
- ✓ Voltage clamp feature
- ✓ **Bi-directional** control for a brushed DC motor.
- ✓ **Acceleration/Deceleration** modify able.
- ✓ **Soft Left/Right Home sensor**
- ✓ MOSFETs are switched at 16 KHz for quiet operation.
- ✓ 2 push buttons for fast test and manual operation.
- ✓ 1 push buttons for configuration
- ✓ Cooling fan control to manager the temperature.
- ✓ Communication support: **PWM/Dir, PWM Bi-direction, Analog/Dir, Analog Bi-Direction, Uart, PPM signal.**
- ✓ Protection support: **Under voltage, Over voltage, Over temperature, Over Current.**
- ✓ **No polarity protection for V motor.**

2. Specification and Operating Enviroment

Mechanical Specification

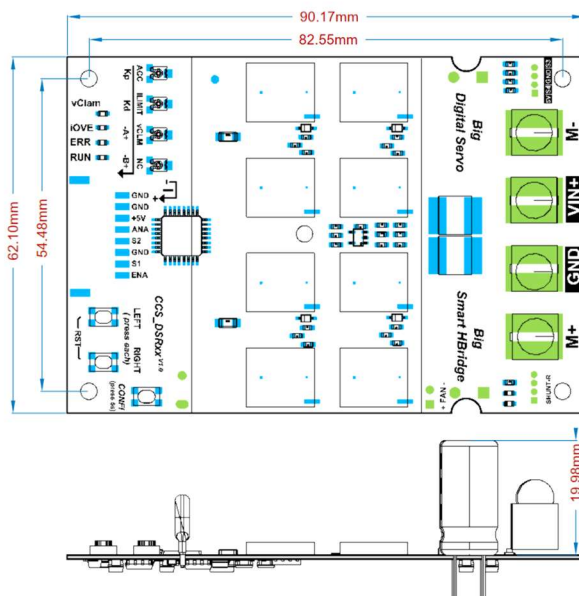

Elimination of Heat

- ❖ Driver's reliable working temperature should be <math><100^{\circ}\text{C}</math>
- ❖ It is recommended to mount the driver vertically to maximize heat sink area.

Electrical Specifications (T_j = 25°C /77°F)

Parameters	CCS_SHB45A			
	Min.	Typical	Max.	Unit
Peak Output Current Per CH	0	-	100	A
Continuous Output Current(*)	0	-	45	A
Power Supply Voltage	+10	-	+55	VDC
V _{IOH} (Logic Input - High Level)	2	-	24	V
V _{IOL} (Logic Input - Low Level)	0	-	0.8	V
+5V Output Current	-	-	250	mA
Analog Pin Range(ANA)	0	-	3.3	V
ENA Pin	0	-	4.2	V

Parameters	CCS_SHB60A			
	Min.	Typical	Max.	Unit
Peak Output Current Per CH	0	-	150	A
Continuous Output Current(*)	0	-	60	A
Power Supply Voltage	+10	-	+55	VDC
V _{IOH} (Logic Input - High Level)	2	-	24	V
V _{IOL} (Logic Input - Low Level)	0	-	0.8	V
+5V Output Current	-	-	250	mA
Analog Pin Range(ANA)	0	-	3.3	V
ENA Pin	0	-	4.2	V

Operating Environment and Parameters

Cooling	Natural cooling or forced cooling	
Operating Environment	Environment	Avoid dust, oil fog and corrosive gases
	Ambient Temperature	0°C—50°C (32°F— 122°F)
	Humidity	40%RH— 90%RH
	Vibration	5.9 m/s ² Max
Storage Temperature	-20°C — 65°C (-4°F — 149°F)	
Weight	Approx. 50 grams	

3. Connections (Note: Please Setting Mode by CONF button)

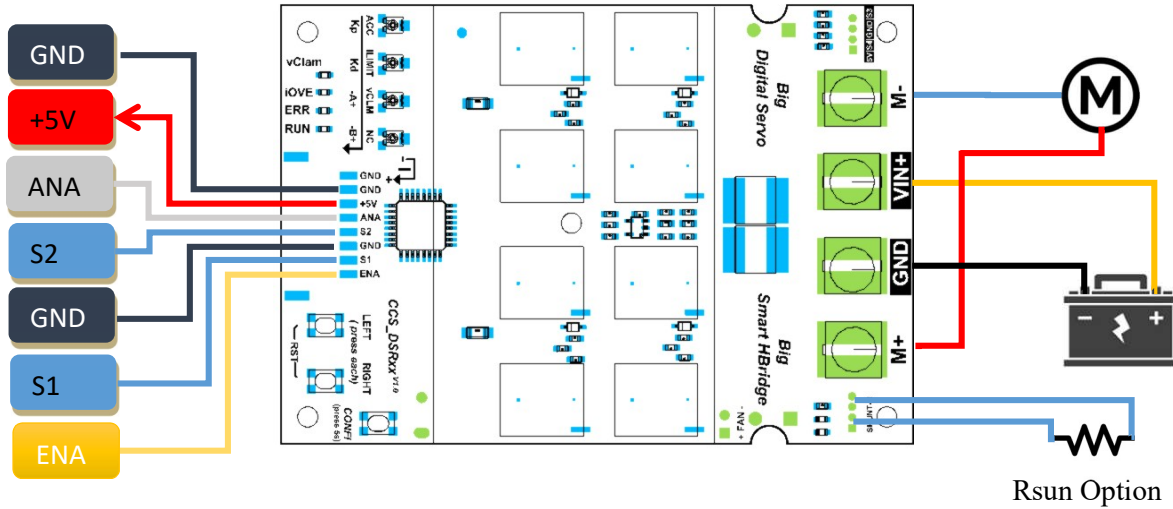

General information

Control Signal			
Pin	Signal	Description	I/O
1	GND	Ground of control signal	GND
2	GND	Ground of control signal	GND
3	+5V	5V, 250mA Output Power	O
4	ANA	Potentiometer Or Analog signal	I
5	S2	DIR/RX	I
6	GND	Ground of control signal	GND
7	S1	PPM/PWM/TX	I
8	ENA	Status and Reset	I/O

POWER and MOTOR Connection			
Pin	Signal	Description	I/O
1	M-	Motor negative connection	O
2	VIN+	10-55V	O
3	GND	Ground of the auxiliary power supply	I
4	M+	Motor positive connection	O

Rclam Header			
Pin	Signal	Description	I/O
1	Rclam	Option: Connect extern Power resistor (1ohm,50W) to discharge the energy from the Motor. (The motor will as a generator and make unexpected voltage increase, This energy will burn the power supply if they increase so high. The Voltage Clamp Feature will discharge that energy via external resistor to protect the power supply.)	O

PWM Bi Direction (or PWM50/50) Mode Connection:

Control the speed and direction of motor without DIR pin but just base on PWM signal.

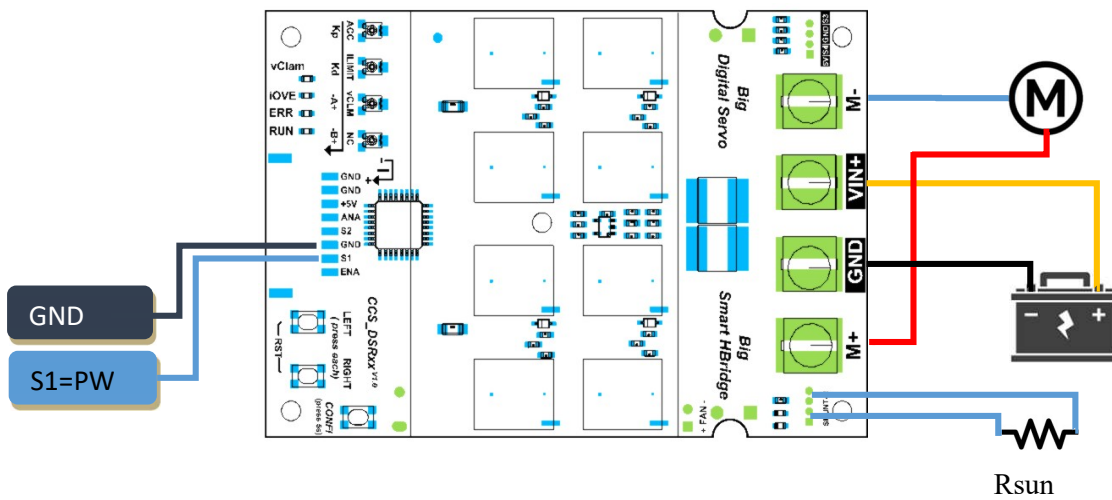

PWM 0-48% ⇔ Velocity 0 – (-Vmax) (forward)

PWM 52-100% ⇔ Velocity 0 – (Vmax) (backward)



PWM/DIR Mode Connection:

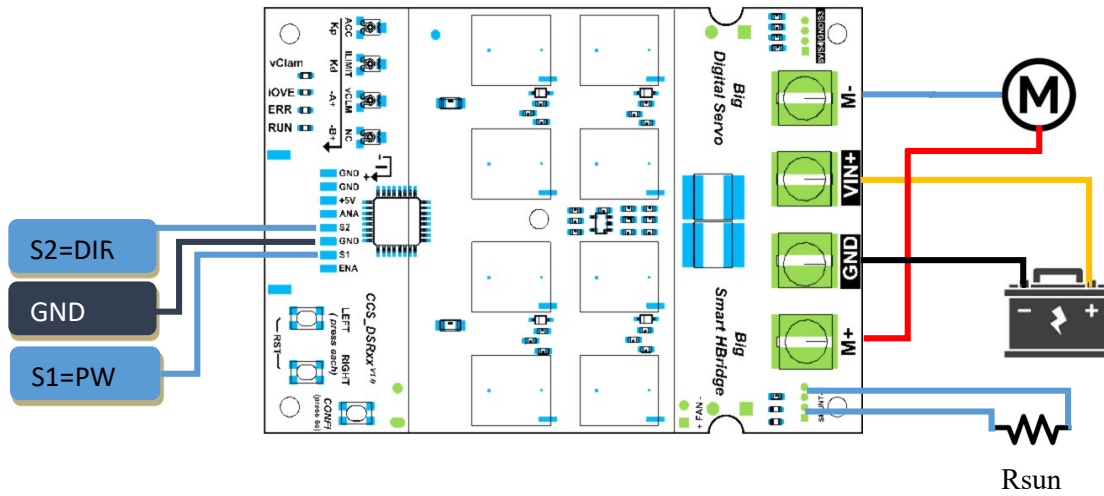

ANALOG/DIR Mode Connection:

A signal from 0-5V can connect to ANA pin to control the driver.

The **speed** will increase from 0 to Max when the signal increase 0-5V.

The **direction** of the motor will depend on the DIR pin logic level.

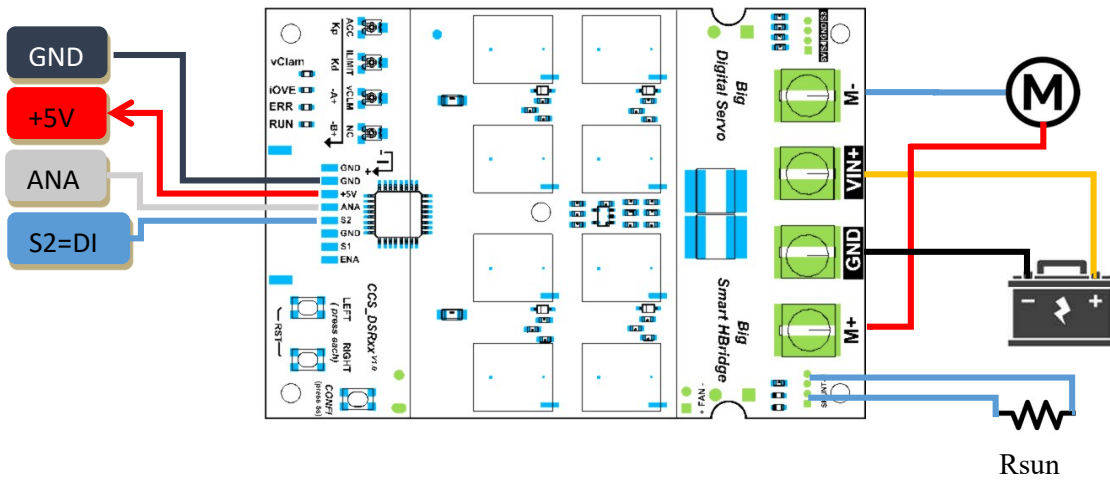

UART Mode Connection:

The user can use UART with TX, RX pin to control the driver by ASCII command.

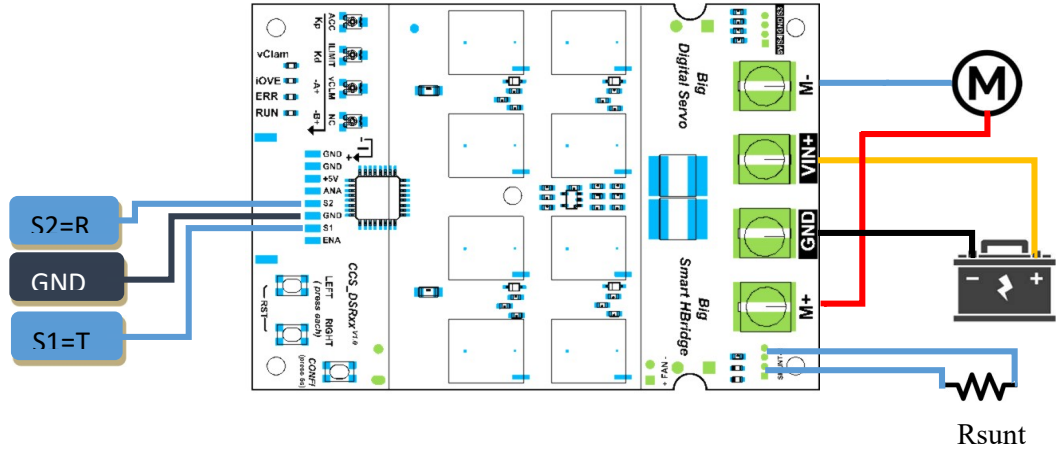

RC Independent Mode Connection:

The RC's RX can control the driver via PPM Signal (Rc signal). Driver can supply 5V for RC's RX. We don't need external power supply for RX.

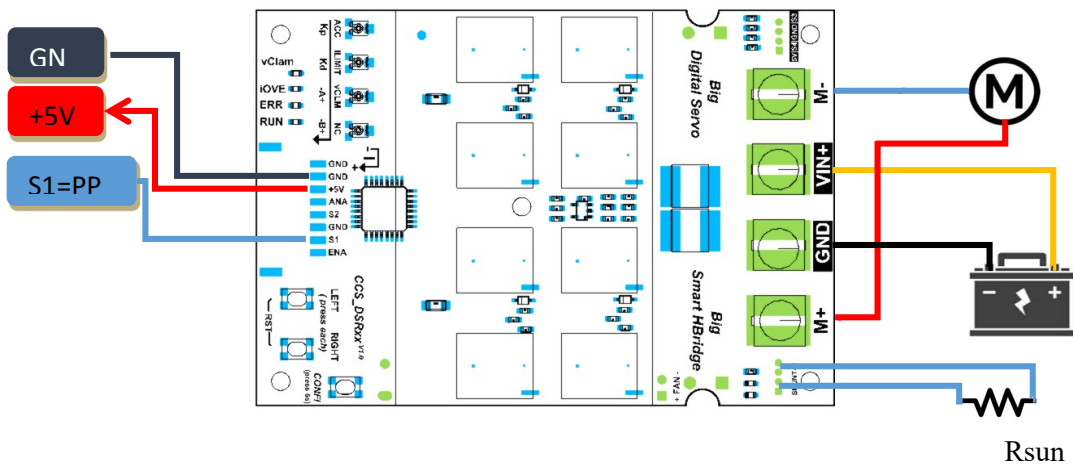

ANALOG Joystick or ANALOG 50/50 Mode Connection:

A signal from 0-5V can connect to ANA pin to control the driver.

The motor will **stop at center point (2.5V)**.

Increase velocity and move to **forward** when the ANA signal **increase** from 2.5V to 5V.

Increase velocity and move to **backward** when the ANA signal **decrease** from 2.5V to 0V.

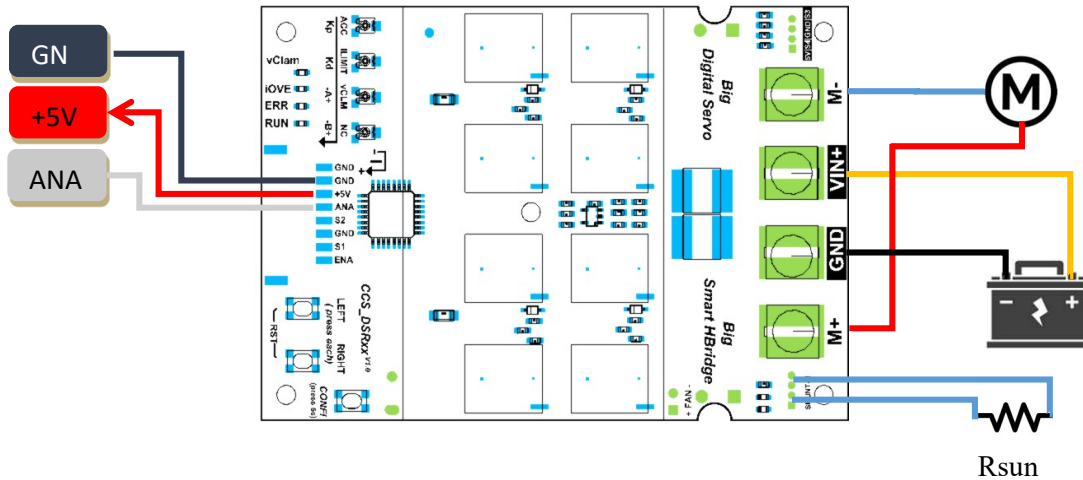

4. UART Command Feature:

This driver support **ASCII UART** command line. User can use UART interface to communicate with the driver.

Any Driver have a **address**. The address can configure by **CONF** button (). Please **configuration the address of the driver differently before using**. They will work as **Slave Mode in the UART Network**. A MCU can work as Mater mode and communicate to many slave (Smart Driver)

Address = (para+1)

Para is setted by CONF button

UART Parameter

- Baud Rate: 115200
- Word Length: 8 Bit
- Stop Bits: 1
- Parity: None

UART Command:

Host Send Format:

Nx [?] [Dy] [dy] [Az] [C] [R1607] [Gj] [S] \n

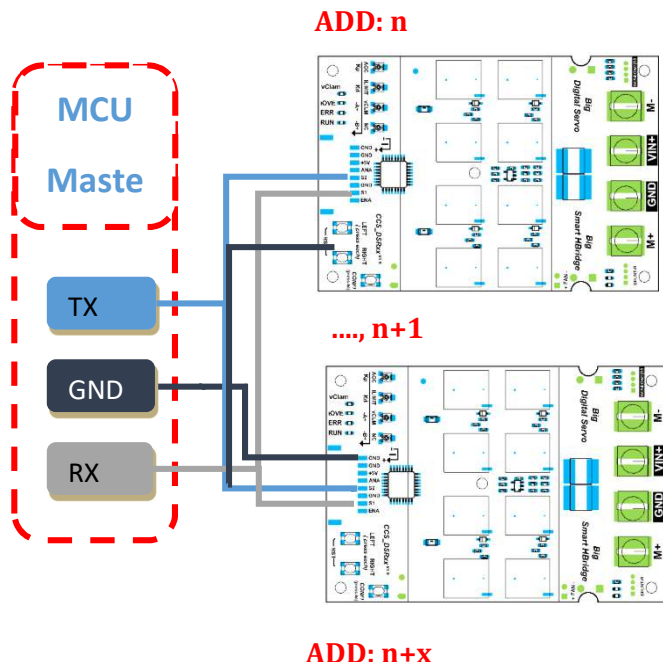

Nx: x = address of driver (0 Broadcast)
?: Help Command, this will ignore other commands (x>0)
Dy: y = duty(-1000 =< y <=1000; y>0: dir=1; y<=0: dir =0)
(D: Duty for Motor)
Az: z= Acceleration(0 =< j <= 65000); z=0: No Ramming
C: Clear error
R1607:Reset MCU
K: Need send back the rx command.
S: Check sum of command S = [atoi(x)] + [atoi(y)] + [atoi(z)]
G: Get driver information (G1: One Time; G3 get to Util new data).
Example1: `N0 ? \n` (Request address of all exist driver in Uart Network)
Example2: `N1 ? \n` (Request Help from driver 1)
Example3: `N1 D500 d400 A200 G3 \n` (Set driver 1 with Motor 1 duty =50% and Motor2 duty =40% and Get state).

Host Request Help from driver X:

`Nx ? \n` (x>0)

Note: With Dy command, The Period of two Frames < 5 second (to keep the bridge running)

5. Configuration:

Input type Configuration:

The driver supports many type of communication method such as PWM/DIR, PPM, UARTs, ...It combine the input Pin to minimum the connection. The Driver use CONF button to config witch type of communication you want. **Please configuration the communication method before using.**

Setting processing:

- ❖ Press and Hold the CONF button more than 5s to enter Config mode. (The Led_iOVER, Led_ERR, Led_Run will blinking, The number of blinking is number function)
- ❖ Press N time to choose Function N. (The Led_iOVER, Led_ERR, Led_Run will blinking N time to indicate function N is choosing.
- ❖ Press and Hold the CONF button more than 5s again to save and exit config mode.

Tip:

1. The config parameter will saved to Flash and used after that
2. When power on **or** changing mode. The Led_Run will blinking a N sequence number to indicate witch mode are configured.

Mode Functions List:

1. RC INDEPEN
2. PWM_DIR_LOW
3. PWM_DIR_HIGH
4. PWM_BI_DIR

5. ANALOG_DIR
6. ANALOG_BI_DIR
7. UART
8. RC_MIXED_RIGHT
9. RC_MIXED_LEFT
10. None
11. Para 1
12. Para 2
13. Para 3
14. Para 4

Acceleration/Deceleration Configuration:

This feature will support to reduce a suddenly changing of velocity. They will protect the mechanical and electrical in many cases.

The **ACCE/DECCE** depend on a Variable Resistors ACCE value in PCB. Please see below picture to know the ACCE Enable/Disable Zone (**Disable Zone: No apply ACCE/DECCE**).

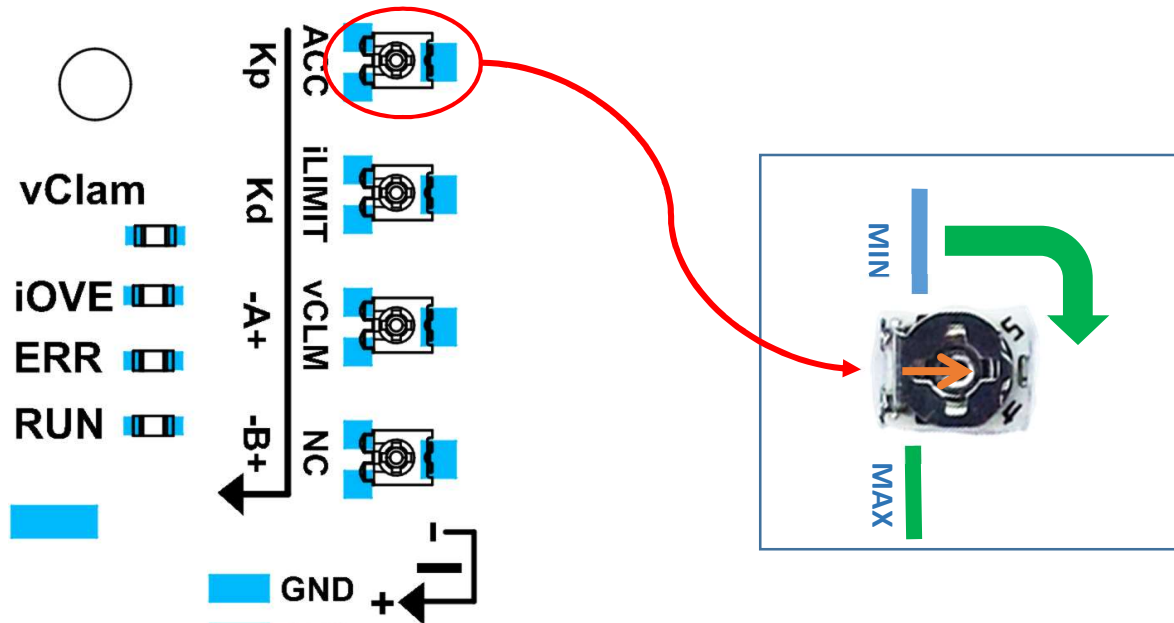

iLIMIT Soft Home Sensor Configuration:

The driver support **Electric Current Home Sensor inside** to limit the moving left and right. It is called **iLIMIT SWITCH**. The user don't need add more extended limit switch. The driver will monitor the current when the Motor is running, if the current of the Motor same as with the iLimit (iLimit is a current limit setting by Variable Resistors in PCB) that mean the mechanical is touched. The driver will set a Touched Flag and stop moving that direction. To moving, the driver need control by reverse direction or the Touched Flag need to be clear by UART Command or short time pull down ENA PIN to reset the driver.

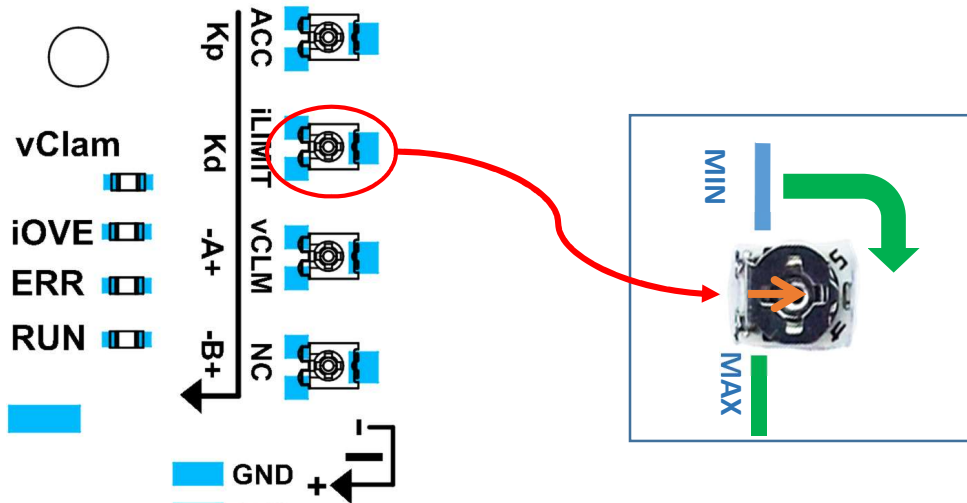

Voltage Clamp Configuration:

The driver will measure the voltage of power supply at the start up time (the voltage when the motor don't move = Voltage_StartUp). This feature allway try to keep the voltage of power near Voltage_StartUp by discharge the energy via a Power Resistor when the voltage of power supply is more than Vclam. **(Note :The feature active when the user connect a external Power Resistor to the driver)**

$$Vclam = Power_Voltage_StartUp + 1.5 + Vol_Trimmer.$$

Vol_Trimmer value range [-1.5V to 1.5V]

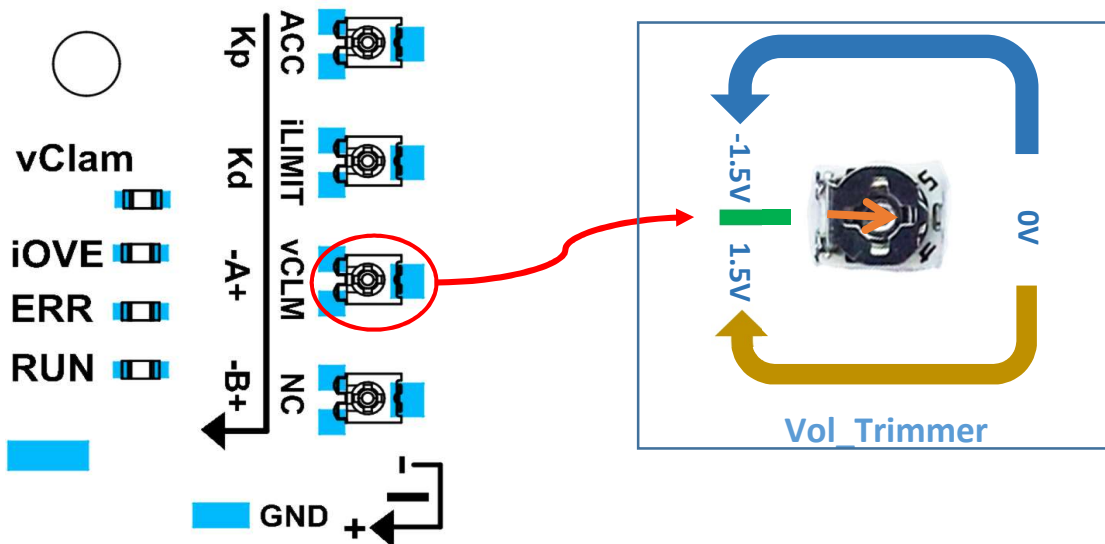

LEFT & RIGHT User Button:

Reset the Driver: short press LEFT and RIGHT BUTTON same time to reset the driver.

MOTOR forced Turn Right: Short press RIGHT BUTTON

MOTOR forced Turn Left: Short press the LEFT BUTTON

6. Protection & Indication Feature:

Protection:

Under/Over Voltage (vBus):

The motor driver output will be shut down when the power input voltage drops below the lower limit. This is to make sure the MOSFETs have sufficient voltage to fully turn on and do not overheat. ERR LED will blink during under voltage shutdown.

Temperature Protection:

The maximum current limiting threshold is determined by the board temperature. The higher the board temperature, the lower the current limiting threshold. This way, the driver is able to deliver its full potential depending on the actual condition without damaging the MOSFETs.

Overcurrent Protection with Active Current Limiting

When the motor is trying to draw more current than what the motor driver can supply, the PWM to the motor will be chopped off and the motor current will be maintained at maximum current limit. This prevents the motor driver from damage when the motor stalls or an oversized motor is hooked up. OC LED will turn on when current limiting is in action.

Indication:

RUN LED Blinking	Description (when MCU Reset or Changing the Mode)
1	PWM 50/50 Mode
2	PWM DIR Mode
3	ANA/DIR Mode
4	UART Command Mode
5	RC (PPM signal) Mode
6	Analog Joystick Mode

ERR LED Blinking	Description
1	Under/Over Voltage
2	Over Temperature
3	Over Current
4	No RC signal is detected or the pulse width is out of acceptable range.

iOVER LED ON/OFF	Description
OFF	The iLIMIT Soft Switch don't touch
ON	The iLIMIT Soft Switch touched

7. ENABLE/STATUS Pin Feature:

The ENA Pin is special PIN with Input and out-put ability.

This Pin will pull up to 5V by the driver after Reset state. And pull down if there are any error. The user can read state of this Pin to know the status of driver.

The user can also Reset the driver by config the MCU Pin is a output Pin and set this Pin to GND about 0.5 second and reconfig MCU Pin as input pin to read the status of the driver.

Please reconfig the MCU pin to input after forced Reset the driver

If you don't need to know the status of the driver or reset the driver by MCU, please let it is free.

8. Recommendation:

Wire Gauge

The smaller wire diameter (lower gauge), the higher impedance. Higher impedance wire will broadcast more noise than lower impedance wire. Therefore, when selecting the wire gauge, it is preferable to select lower gauge (i.e. larger diameter) wire. This recommendation becomes more critical as the cable length increases. Use the following table to select the appropriate wire size to use in your application.

Current (A)	Minimum wire size (AWG)
10	#20
15	#18
20	#16

System Grounding

Good grounding practices help reduce the majority of noise present in a system. All common grounds within an isolated system should be tied to PE (protective earth) through a 'SINGLE' low resistance point. Avoiding repetitive links to PE creating ground loops, which are a frequent source of noise. Central point grounding should also be applied to cable shielding; shields should be open on one end and grounded on the other. Close attention should also be given to chassis wires. For example, motors are typically supplied with a chassis wire. If this chassis wire is connected to PE, but the motor chassis itself is attached to the machine frame, which is also connected to PE, a ground loop will be created. Wires used for grounding should be of a heavy gauge and as short as possible. Unused wiring should also be grounded when safe to do so since wires left floating can act as large antennas, which contribute to EMI.

Power Supply Connection

NEVER connect power and ground in the wrong direction, because it will damage the driver. The distance between the DC power supply of the drive and the drive itself should

be as short as possible since the cable between the two is a source of noise. When the power supply lines are longer than 50 cm, a **1000 μ F/100V** electrolytic capacitor should be connected between the terminal “GND” and the terminal “+VDC”. This capacitor stabilizes the voltage supplied to the drive as well as filters noise on the power supply line. **Please note that the polarity can't be reversed.**

It is recommended to have multiple drivers to share one power supply to reduce cost if the supply has enough capacity. To avoid cross interference, **DO NOT** daisy-chain the power supply input pins of the drivers. Instead, please connect them to power supply separately.